

THORN

Zoria

A unique collection of functional and decorative column and bracket packages for fully harmonised design achievement

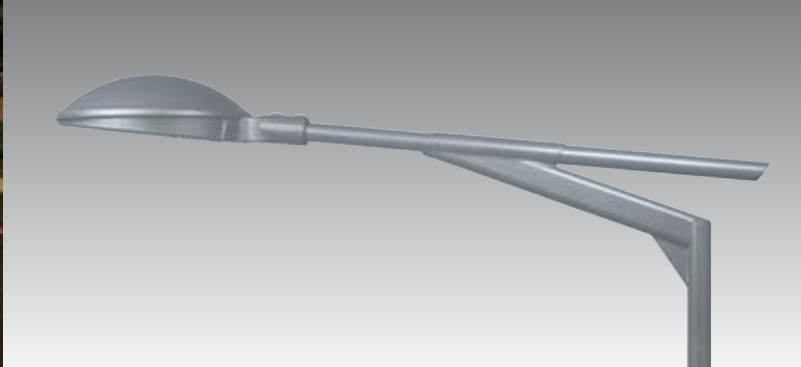
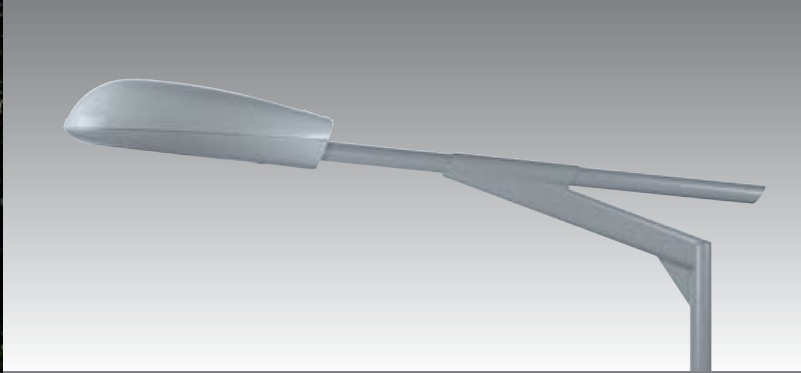
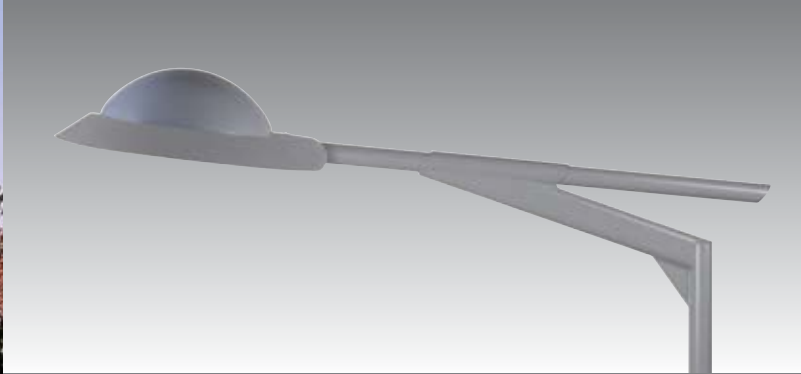
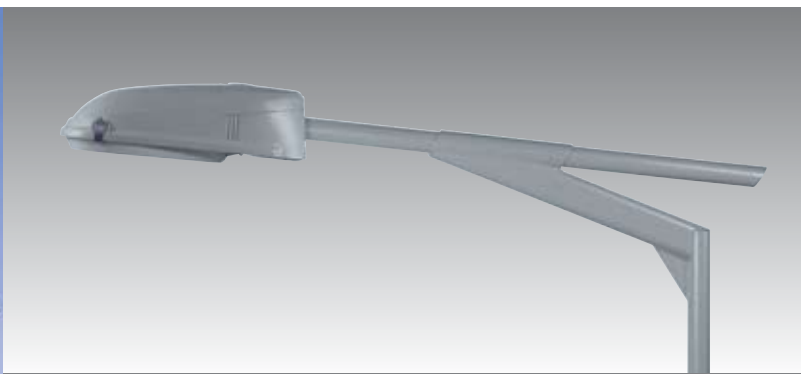

Zoria - for functional and decorative road lighting applications

This range of tapered lighting columns and harmonised brackets enables the designer to achieve a fully integrated lighting design strategy for towns and cities

- Columns are in steel with flanged plate mounting
- Heights range from 6-10m and complementary single, twin arms or wall brackets are offered to suit the needs of different projects
- For each type there are versions suited and detailed to accept a wide range of side entry Thorn lanterns
- Easy integration into the urban landscape
- Bracket delivered assembled ready for contractor to install
- Complies with EN40, ensuring safe installation
- Easy installation and maintenance
- Durable aluminium/stainless steel construction
- Fully recyclable
- Standard finish is RAL9006, other RAL colours available on request to match your project requirements

Standards

Designed and manufactured to comply with EN 40-5 **CE**

What is EN40?

A European standard, in force since 1st February 2005, that guarantees the calculation of column packages (column, bracket, lantern) for an installation in a given site and imposes CE marking on columns. This guarantee is obtained through an agreement delivered by a European Organisation. Thorn's Les Andelys production site has been certified by CTICM on 7th February, 2006.



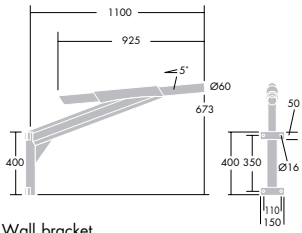
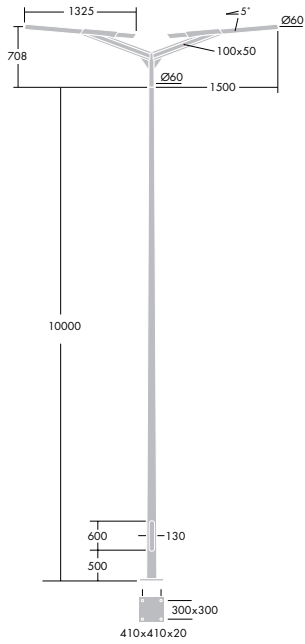
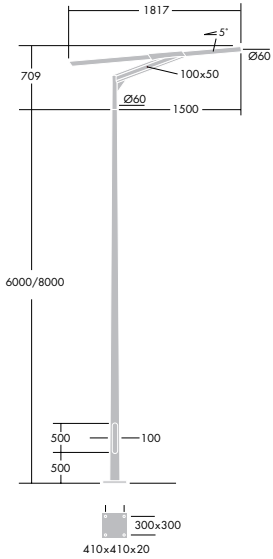
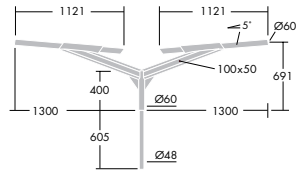
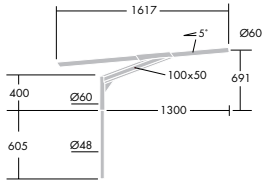

Wall bracket



Dyana



Oracle



Decostreet



Civic

Ordering Guide

Type	Pole Height (m)	Bracket Type	Out-reach (m)	Description	Wt (Kg)	SAP code
Bracket Arms Packages and Poles	6	Single	1.3	ZORIA COLUMN 6M + SINGLE BRACKET 1.3M	95	99078830
			1.5	ZORIA COLUMN 6M + SINGLE BRACKET 1.5M	95	99078841
		Twin	1.3	ZORIA COLUMN 6M + TWIN BRACKET 1.3M	114	99078832
			1.5	ZORIA COLUMN 6M + TWIN BRACKET 1.5M	114	99078842
	8	Single	1.3	ZORIA COLUMN 8M + SINGLE BRACKET 1.3M	176	99078833
			1.5	ZORIA COLUMN 8M + SINGLE BRACKET 1.5M	176	99078843
		Twin	1.3	ZORIA COLUMN 8M + TWIN BRACKET 1.3M	195	99078837
			1.5	ZORIA COLUMN 8M + TWIN BRACKET 1.5M	195	99078845
Bracket Arm	10	Single	1.3	ZORIA COLUMN 10M + SINGLE BRACKET 1.3M	220	99078838
			1.5	ZORIA COLUMN 10M + SINGLE BRACKET 1.5M	220	99078846
		Twin	1.3	ZORIA COLUMN 10M + TWIN BRACKET 1.3M	239	99078839
			1.5	ZORIA COLUMN 10M + TWIN BRACKET 1.5M	239	99078847
		Single	1.3	ZORIA SINGLE BRACKET 1.3M FOR TOP 60	20	99074862
			1.5	ZORIA SINGLE BRACKET 1.5M FOR TOP 60	20	99074867
Wall Bracket		Twin	1.3	ZORIA TWIN BRACKET 1.3M FOR TOP 60	36	99074863
			1.5	ZORIA TWIN BRACKET 1.5M FOR TOP 60	36	99074868
		Single	1.3	ZORIA SINGLE BRACKET 1.3M FOR TOP 76	20	99074865
			1.5	ZORIA SINGLE BRACKET 1.5M FOR TOP 76	20	99074870
	Twin	1.3	ZORIA TWIN BRACKET 1.3M FOR TOP 76	36	99074866	
		1.5	ZORIA TWIN BRACKET 1.5M FOR TOP 76	36	99074871	



THORN

Lighting people and places

Hovedkontor

Thorn Lighting AS

Strømsveien 344
1081 Oslo
Tlf 22 82 07 00
Fax 22 82 07 01
Ordrefax 22 82 07 49

www.thornlighting.no

Oslo

Thorn Lighting AS
Strømsveien 344
1081 Oslo
Tlf 22 82 07 00
Fax 22 82 07 01

Fredrikstad

Thorn Lighting AS
Bankbrygga 6
1606 Fredrikstad
Tlf 22 82 07 00
Mob 91 76 54 24
Fax 69 31 38 98

Hamar

Thorn Lighting AS
Kappveien 68
2322 Ridabu
Tlf 22 82 07 00
Mob 45 48 77 19
Mob 90 28 79 39
Fax 62 54 30 91

Drammen

Thorn Lighting AS
Øvre Eiker vei 14
3048 Drammen
Tlf 32 20 14 80
Mob 90 63 54 49
Fax 32 20 14 81

Grenland

Thorn Lighting AS
Herøya Næringspark
Arthur Berbys vei 7
3936 Porsgrunn
Tlf 22 82 07 00
Mob 90 91 58 16
Fax 35 92 22 89

Kristiansand

Thorn Lighting AS
Svartefjell 22
4625 Flekkerøy
Tlf 22 82 07 00
Mob 97 74 42 64
Fax 22 82 07 01

Stavanger

Thorn Lighting AS
Kongleveien 13
4352 Kleppe
Tlf 51 42 66 40
Mob 91 76 53 77
Fax 51 42 66 41

Bergen

Thorn Lighting AS
Kanalveien 55, 5068 Bergen
Postboks 133 Kristianborg,
5822 Bergen
Tlf 55 20 06 60
Fax 55 20 03 60

Molde

Thorn Lighting AS
Amtmann Leths gate 39
6413 Molde
Tlf 73 89 44 00
Mob 92 83 73 35
Fax 71 25 79 93

Trondheim

Thorn Lighting AS
Granåsveien 1
7048 Trondheim
Tlf 73 89 44 00
Fax 73 89 44 02

Bodø

Thorn Lighting AS
Hålogalandsgata 95
8008 Bodø
Tlf 75 52 71 22
Mob 91 76 53 99
Fax 75 52 71 23

Tromsø

Thorn Lighting AS
Håndverkervn. 7A
Postboks 3448
9276 Tromsø
Tlf 77 67 60 70
Mob 95 07 55 22
Fax 77 67 21 51

Thorn Lighting utvikler og forbedrer sine produkter kontinuerlig. Alle beskrivelser, illustrasjoner, tegninger og spesifikasjoner i denne utgivelsen presenterer kun generelle opplysninger og danner ikke noen form for kontrakt. Vi forbeholder oss retten til å endre spesifikasjoner uten forhåndsvarsel eller offentlig kunngjøring. Alle varer som leveres av selskapet leveres i følge våre generelle kjøpsvilkår. En kopi av disse er tilgjengelig ved forespørsel. Alle mål er i millimeter og vekt i kilo, bortsett fra hvis annet er angitt.

Utgivelsesnr: 407 (NO) Utgivelsesdato: 11/07